

# HyPyr-Loss™

## Ultra Hybrid Absorbers - UH Series

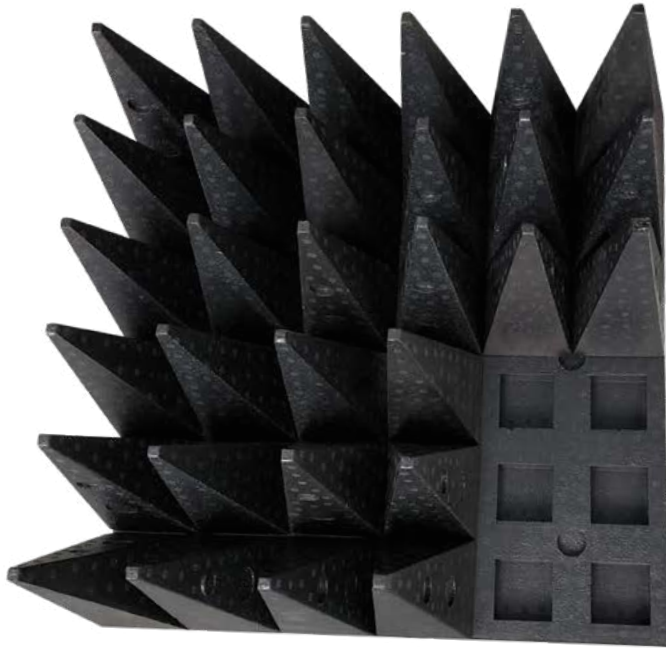

UH Absorbers (shown with white caps) in a Fully Compliant 3m chamber

### SOLUTION FOR

- EMC/EMI chambers
- Mixed-use test facilities
- Pre-compliance & full compliance testing

### Main features

- Excellent broadband performance (used with ferrite tiles)
- High uniformity and isotropy
- Optimized impedance match with ferrite tiles
- Repeatable and accurate results
- Clean-room compatible
- Durable and Long-lasting (up to 35 years)

### Product configuration

#### Shape

- Hybrid Pyramid Absorber

#### Material

- Polypropylene

#### Frequency band

- From 30 MHz to 40 GHz

#### Standard base size

- 1.97' x 1.97' (60 x 60 cm)

#### Height

- 30 cm to 75 cm

#### Operating conditions

- Temperature: up to 90°C

#### Indoor/outdoor

- Indoor/Outdoor

MVG-EMC offers a full array of high-performance absorber materials specifically designed to meet the increased demands of today's EMC testing requirements. The HyPyr-Loss™, UH product line, is designed to satisfy all of today's EMC applications and product standards. Ask our design engineers to help you select the right absorber for your application.



### Ferrite Hybrid Technology

ULTRA UH series polypropylene based hybrid electromagnetic absorbers are the latest technology for EMC/RF test applications. The polypropylene material has a highly uniform carbon density, throughout the material, which provides for more predictable results with no discontinuities. It is the unique production technology which is the critical factor in achieving the highest electromagnetic reflectivity performance in an MVG test chamber.

UH series absorbers are accurately produced by using precise molding techniques that ensure all products have the same shape and size, which is a very important feature for fast installation and, a high quality finish to the chamber interior. The UH series includes several different model designs UH30, UH50 and UH75. This enables each of the test ranges to achieve full compliance as per CISPR 16, ANSI C63.4, IEC61000-4-3 and other international standards. The UH series provides an exceptional wideband performance for EMC test chamber applications in the frequency range from 30 MHz to 40 GHz and above.

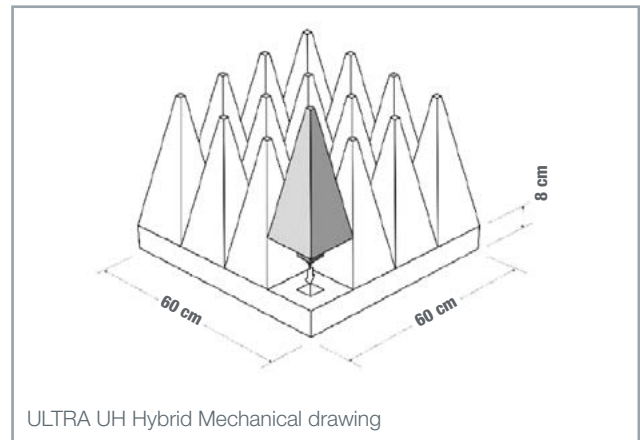

### The benefits of ULTRA UH Polypropylene Absorbers

- Super Ultra-Wideband Electromagnetic Absorber
- High Quality and High Performance
- Lightweight and Strong (maintains shape)
- Superior Product Lifetime (over 35 years)
- Optimum Impedance Match with Ferrite Tiles
- Impervious to Changes in Humidity (non-hydroscopic)
- Modular and Easy to Install
- Optimum Isotropy (uniformity in all orientations)
- Extremely Low Maintenance
- Eco-friendly Green Products

### ORDERING CODE

- UHXX, where XX designates absorber height in cm.

### Specifications

		UH30	UH50	UH75
Height	cm	30	50	75
Absorption @ Normal Incidence	@ 30 MHz	18	19	21
	@ 100 MHz	23	23	22
	@ 300 MHz	21	21	22
	@ 500 MHz	17	19	21
	@ 700 MHz	16	19	22
	@ 1 GHz	15	20	24
	@ 3 GHz	18	25	29
	@ 6 GHz	23	30	35
	@ 10 GHz	27	36	40
	@ 13 GHz	29	39	43
@ 18 GHz	32	43	47	
RF Power handling		1.5 kW/m <sup>2</sup> or 750 W/m		
Weight	kg	1.9	4.1	5.3
No. of Pyramid points		36	16	9
Fire retardancy		DIN4102 Class B2, UL94HBF		
Clean room standard		ISO14644 Class 4		
UV certification		ISO 4892-2:2013		



Contact your local sales representative for more information

[www.mvg-world.com/absorbers](http://www.mvg-world.com/absorbers)

[salesteam@mvg-world.com](mailto:salesteam@mvg-world.com)